

UNIT 22 *Volume*

Extra Exercises 22.1

1. Calculate the volume of each of the shapes below:

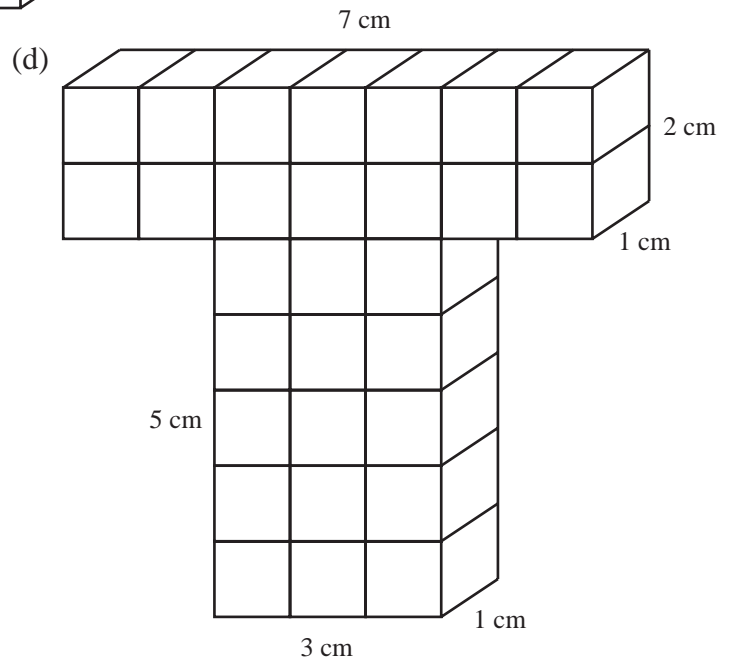
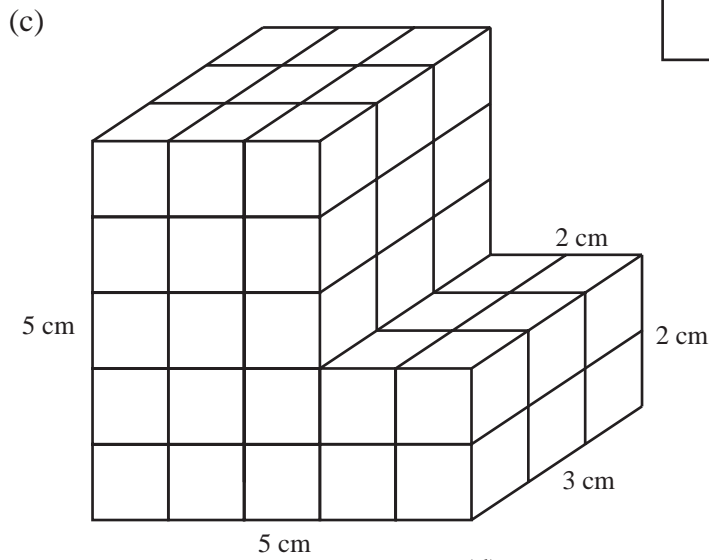
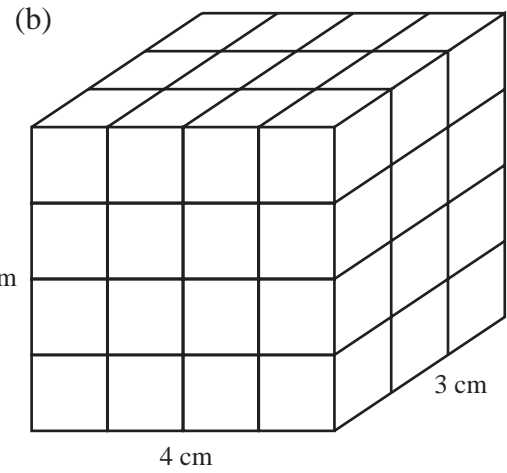
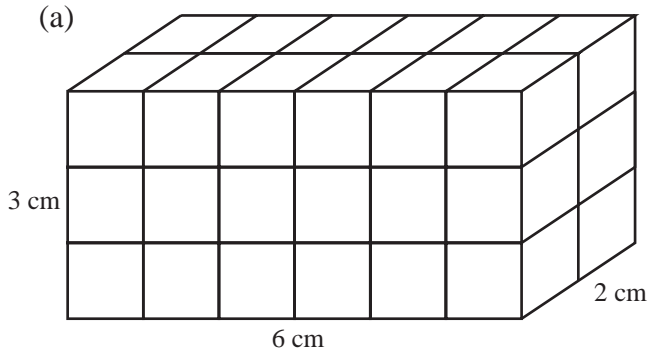

Extra Exercises 22.1

2. A cuboid is to be made from 1 cm cubes placed on a rectangular base. The size of the base is 4 cm by 5 cm.
- (a) How many cubes are used to form the first layer of cubes?
 - (b) How many cubes are used in the cuboid if it is 10 cm high?

UNIT 22 *Volume***Extra Exercises 22.2**

- Calculate the volume of cubes with sides of length:
 - 8 cm
 - 12 cm.
- A cube has sides of length 20 cm. Calculate the volume of the cube in:
 - cm^3 ,
 - m^3
- A large box is a cube with sides of length 50 cm. Small cubes have sides of length 10 cm.
 - Calculate the volume of the large box.
 - Calculate the volume of a small cube.
 - How many small cubes will fit into the large box?
- A box is a cube with sides of length 0.4 m. Calculate the volume of the box in:
 - m^3 ,
 - cm^3 .
- The shape below is built from cubes with sides of length 2 cm.

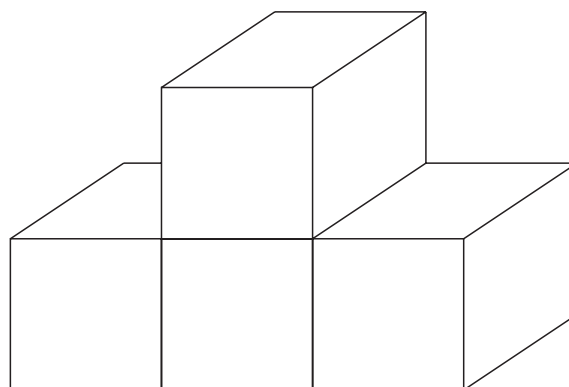

What is the volume of the shape?

UNIT 22 *Volume*

Extra Exercises 22.3

1. Calculate the volume of each of the cuboids below:

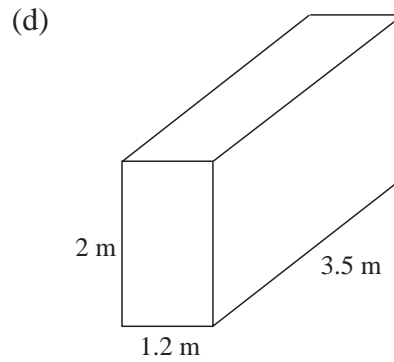
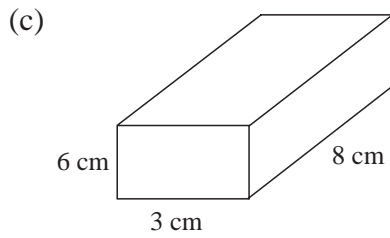
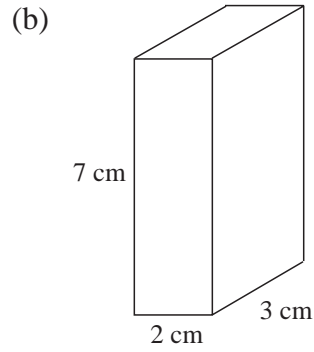
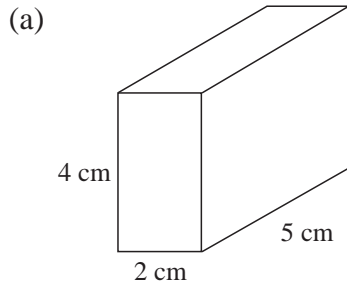

2. Calculate the volume of each of the shapes below:

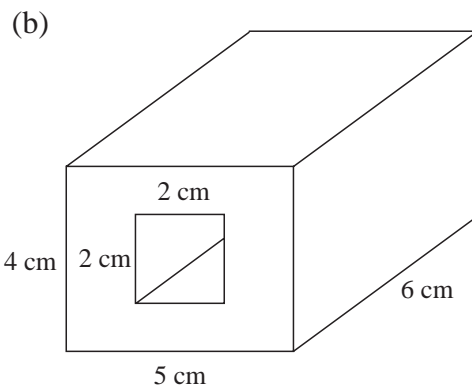
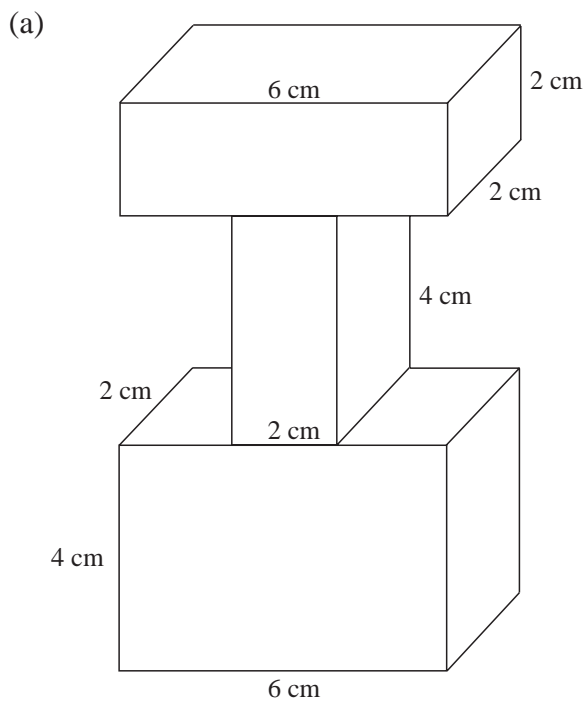

Extra Exercises 22.3

3. A box, with sides of length 6 cm, 12 cm and 10 cm, is put into a larger box which has sides of length 10 cm, 20 cm and 30 cm.
Calculate the volume of the empty space in the larger box.

UNIT 22 *Volume***Extra Exercises 22.4**

1. Copy and complete the table below:

<i>Volume in litres</i>	<i>Volume in cm³</i>
8	
3	
0.5	
0.2	
	6000
	3000
	3500
	800
	1200

2. A tank has sides of length 2 m, 2 m and 1 m.

Calculate the capacity of the tank in:

- (a) m³
(b) cm³
(c) litres.
3. A plastic bottle holds 125 cm³ of drink. How many bottles can be filled from 6 litres of drink?
4. A tank has a base with sides of length 60 cm by 40 cm. The water in the tank is 50 cm deep. A rock is placed in the tank and the water rises by 20 cm. Calculate the volume of the rock.

UNIT 22 *Volume***Extra Exercises 22.5**

- The density of water is 1 gram/cm^3 .
Calculate the mass of the following volumes of water:
(a) 700 cm^3 (b) 3 litres (c) 3 m^3 .
- A metal block has a mass of 0.6 kg. The dimensions of the block are shown below:

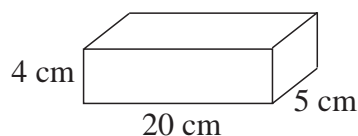

Calculate the density of the metal in:

- grams/ cm^3 ,
 - kg/ m^3 .
- The density of sea water is greater than the density of pure water. The mass of 20 litres of sea water is 21 kg.
Calculate the density of this mass of sea water.
 - Two samples, X and XX, of different types of soil are brought to a laboratory in full boxes. Use the information below to find the density of each soil sample:

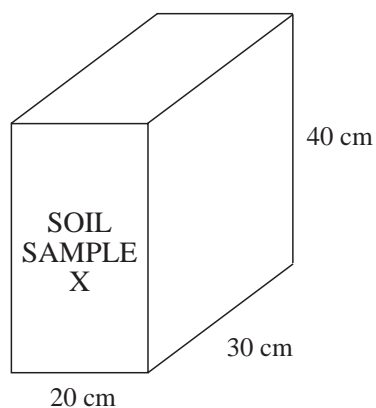

19.2 kg

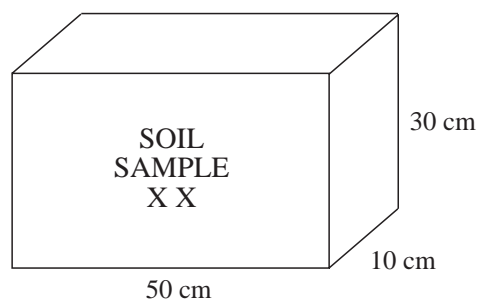

10.5 kg

UNIT 22 Volume

Extra Exercises 22.6

1. Calculate the volume of each of these triangular prisms:

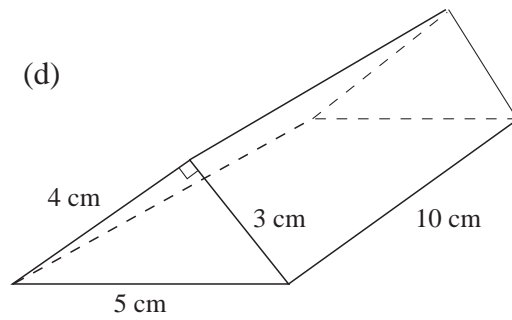
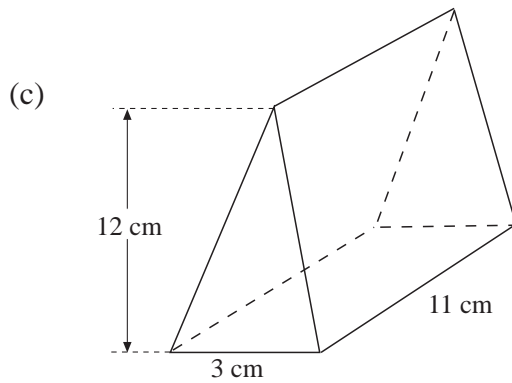
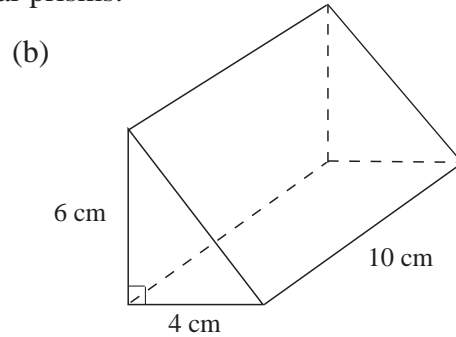
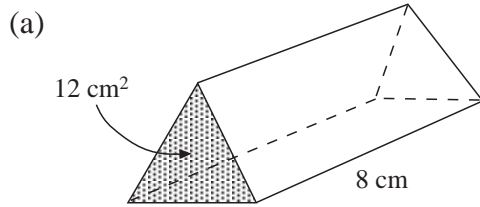

2. The prism below has volume 78 cm^3 . What is the area of the shaded face of the prism?

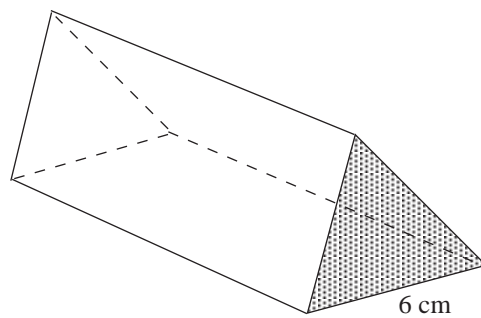

3. The area of cross-section of a prism is 15 cm^2 . If the volume of the prism is 750 cm^3 , what is its length?

Extra Exercises 22.1

Answers

1. (a) 36 cm^3 (b) 48 cm^3 (c) 57 cm^3 (d) 29 cm^3
2. (a) 20 (b) 200

Extra Exercises 22.2

Answers

1. (a) 512 cm^3 (b) 1728 cm^3
2. (a) 8000 cm^3 (b) 0.008 m^3
3. (a) $125\,000 \text{ cm}^3$ (b) 1000 cm^3 (c) 125 cubes
4. (a) 00.064 m^3 (b) $64\,000 \text{ cm}^3$
5. 32 cm^3

Extra Exercises 22.3

Answers

1. (a) 40 cm^3 (b) 42 cm^3 (c) 144 cm^3 (d) 8.4 m^3
2. (a) 88 cm^3 (b) 96 cm^3
3. (a) 5280 cm^3

